

HILCREST RANGE

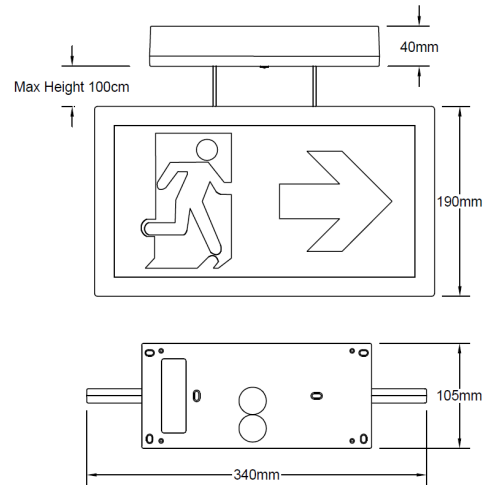

The Hilcrest range presents a stylish and compact double-sided LED suspended exit sign. You can choose between a switchable maintained/non-maintained, DALI-2 self-test, or a MyMesh Ready wireless version. The fitting comes with a PMMA screen-printed legend plate that allows you to view the sign from a distance of up to 30m.

The Hilcrest range is supplied with 1m suspensions and arrow up (AU), arrow down (AD), arrow left (AL) and arrow right legend panels. The Lithium Iron Phosphate (LiFePO4) batteries used in the unit not only offer double the life of traditional emergency lighting batteries but also consume less power during their operation.

Part code	Charging M*	Charging NM*	Duration	Cells	Weight
	W	W	hrs	LiFePO4	kg
TLHIL/M	5.7	0.2	3	3.2V 3.8Ah	1.2
TLHIL/ST	5.4	0.3	3	3.2V 3.8Ah	1.2
TLHIL/DA	5.4	0.3	3	3.2V 3.8Ah	1.2
TLHIL/ME	5.6	0.5	3	3.2V 3.8Ah	1.2

* Following its initial charge, the unit will spend 90% of its operational life in standby mode.

M = Switched Maintained ST = Self Test Emergency DA = DALI Addressable ME = Mymesh Emergency
SL** = Slave